

Mini Labeller Rectangular



GERMARK
IDENTIFICATION SOLUTIONS

Machine Specifications



Perfect for small productions and as initiation to the automatic labelling world

Dimensions

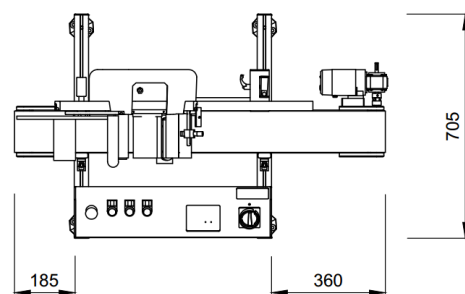
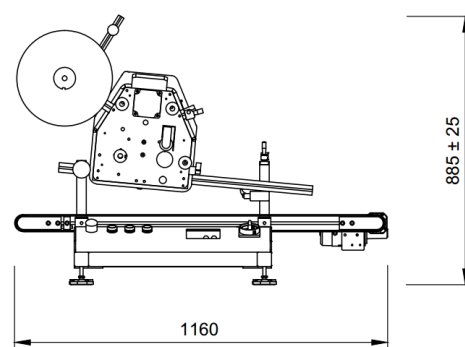

Labelling Options



Measures of the product to label:

Height: 15 mm – 75 mm
Width: 15 mm – 140 mm

General Features

Maximum line speed	12 m/min
Changes of format	Yes, in an easy and comfortable way
Different options	Thermoprinter, End-of-reel control, Label-on-product control, Reprint control, Luminic/acoustic informants, Transparent labels detector, Labelled product collection tray, Product spacer
Control panel	Easy use with all the controls for the daily use of the labelling machine
HMI	Multilingual
	Different configuration options of the machine
	Possibility of saving up to 20 different programs
Good finishing guaranteed	

Technical Data

Voltage/Frequency	220V – 50 Hz
Consume	1000 W
Dimensions	885 x 705 x 1160
Weight	45 kg

Technical Specifications

Label reel dimensions	Maximum width	115 mm
	Minimum width	10 mm
	Minimum length	10 mm
Label reel capacity	Maximum external diameter	300 mm
	Internal diameter	76 mm

Including Technical Documentation of the Equipment

User's Guide

Electrical Schemas

Declaration of Conformity and Market CE