

Multibox SVTE

Machine Specifications

3 in 1



GERMARK
IDENTIFICATION SOLUTIONS



Dimensions

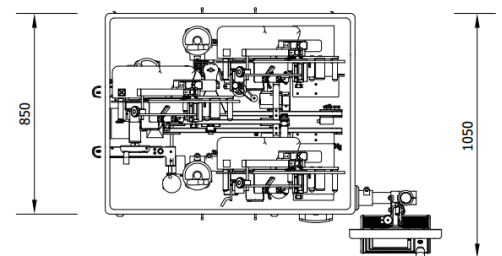
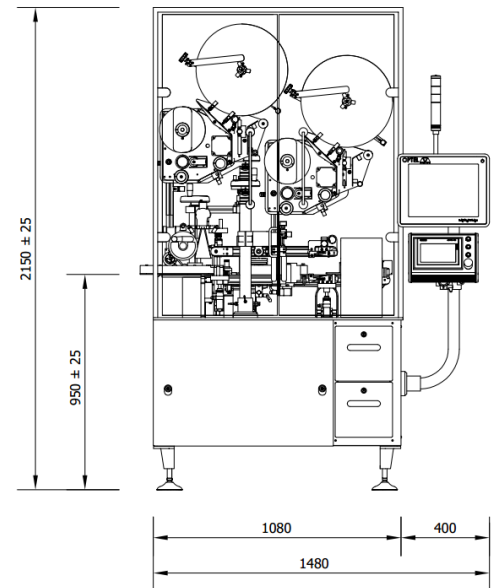

Options to be labelled

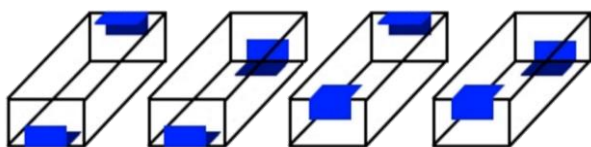

Product to be labelled

X: From 65mm to 200mm

Y: From 20mm to 200mm

Z: From 30mm to 200mm

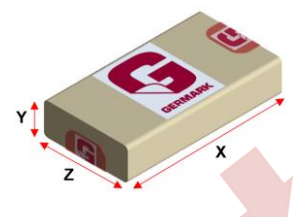

General Features

Functions	Serialisation (with partner), vignette, TE
Ergonomics	
Conveying System	Servo driven upper and lower belts
Maximum Line Speed	40 m/min
Changes of Format	No tools required , Threading spindles, digital display
Dimensions of HMI	7"
Configurable Software	Recipes for diferent products
Swing Arm Electric Panel	Easy Access
Quick Change System	Yes
Ejection Station Trays	Vignette, TE, Serial print

Technical Data

Voltage/Frequency	230 VAC - 50 Hz
Dimensions SVTE + CW	1480 x 450 x 2150
Weight	150 Kg
Air pressure	6 bar

S - Serialisation P&V

Printer (ordered optionally)	Videojet Wolke OEM600 as standard single or twin as option
Camera and software	Prepared for serialisation ready
Supports and accesories	Brackets, guides, sensors
Integration	

TE - Tamper-evident

Labeler head	PB115: Adjustable column with digital position indicators, sensory, automatic unwinding
Presence sensor	Optic sensor
Folding guides	Fixed guides

V - Vignette

Labeler head	PB115: Adjustable column with digital position indicators, sensory, automatic unwinding
Camera and software	
Integration	

Including Technical Dcumentation of the Equipment

User's guide	
Technical guide	
Detailed parts	
Electrical schemas	
Declaration of conformity and market CE	