



pack'solutions
customized

Pharma | Cosmetics

Food

Non-Food

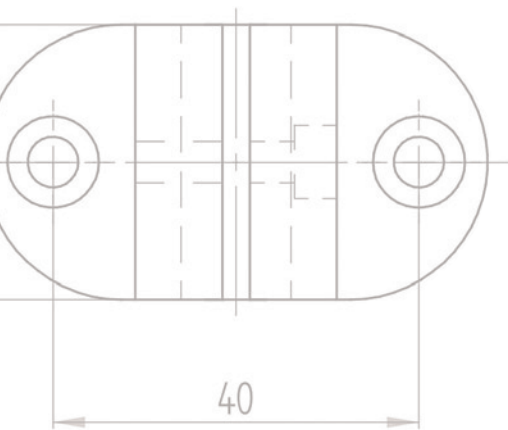

Semiautomatic packaging machinery

oli 310 operating principle with case blanks

oli 310 - Side Loading

- » Suitable for all conventional types of cases or products, especially for stackable products like folding boxes, bundles, cans, bottles, etc.
- » Packages are fed, stacked and inserted into the case fully automatically
- » Quick and easy format change
- » Modular design extendable with the olimat + oli-pal to operate as a fully automatic final packaging line
- » Processing is gentle on products offering highest process safety

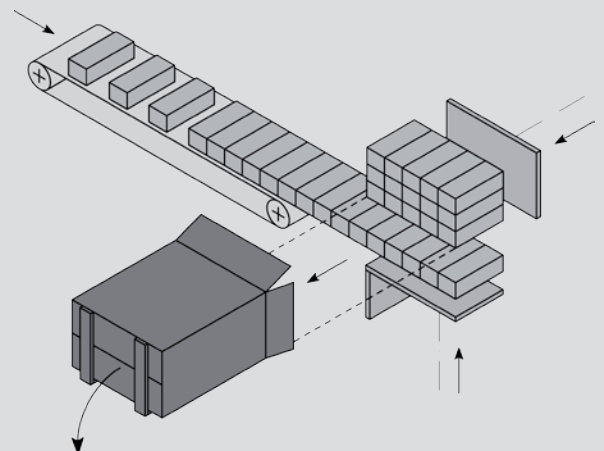

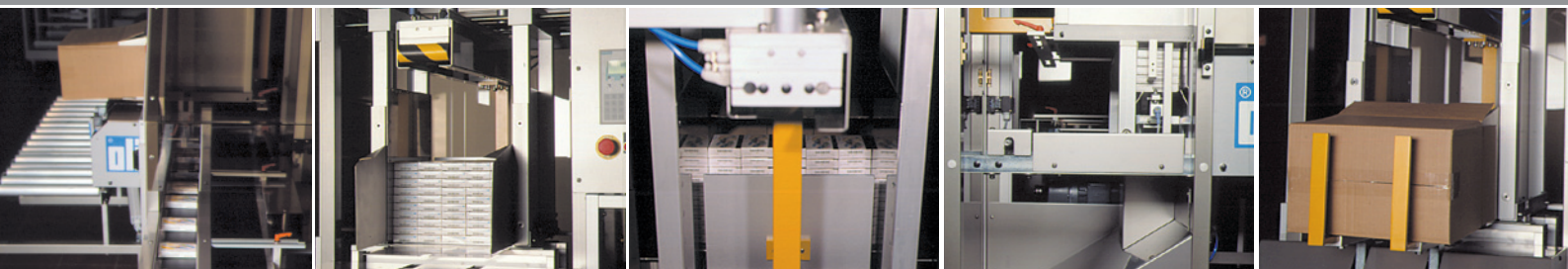

» Packaging feed with back up sensor

» Stacker and push-off unit

» Side view with stacker unit and GMP panelling

» Push-off unit, rear view

» Erected American case and case forks

Semiautomatic packaging machinery oli 310 - Side Loading

Standard features of this installation include the

- » **oli 310 cartoning machine** as a collation module.
- Easily extendable with the
- » **olimat 3D** or the **olimat 1 case erector/sealer**



olimat 3D

The **oli-pal** or the **oli-pal Duplex compact palletiser** extend **oli 310** to operate as a fully automatic final packaging line.

General information:

Can be applied in all industries. Pharmaceutical compliant GMP, compact and space-saving design. Superior workmanship/material quality and refined operability in all details:

- » All components are readily accessible
- » Easy to clean
- » Especially compact design
- » Operator panel with multi-lingual text display or touchscreen panel
- » Quick format change
- » Servo motors drive all relevant motion on request; state-of-the-art PLC control system
- » Practically maintenance free

Technical information:

Output: suitable for up to 5 cases/min
 Case format range (L x W x H mm): 200-500 x 60-400 x 60-500 or according to customer preference
 Operating voltage/required power: 3 x 230/400 V/N/PE, 50/60 Hz, 0.3 kVA
 Air pressure: 6 bar
 Floor layouts: Left or right-hand variants to customer preference
 Change over time: approx. 5 - 15 min

Note:

oli packaging machinery is customized in terms of output, colour, installed load, etc., to suit the specific customer application. All machinery can be designed inversely for every format.

Layout oli 310

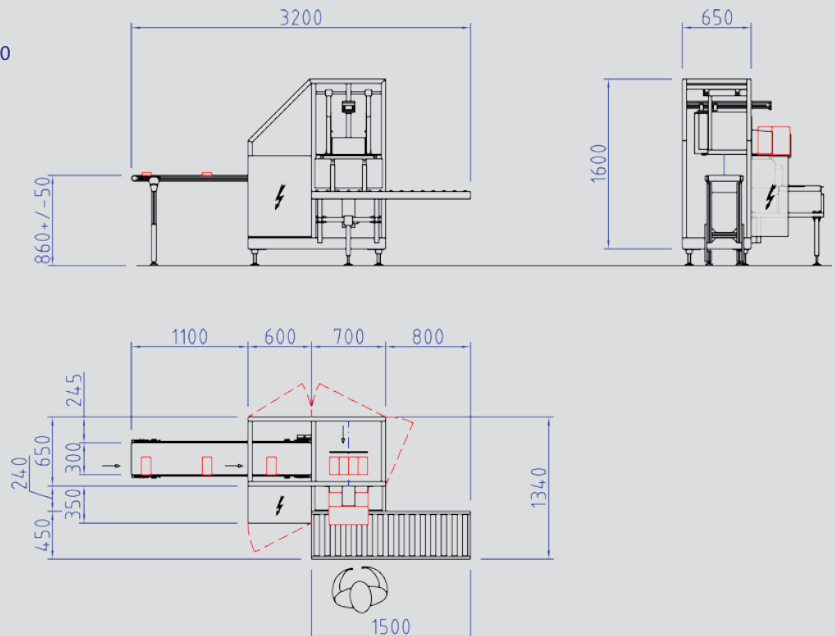

O. Lingenfelder
oli-Spezialanlagen GmbH

Blumenstraße 17-21
 82538 Geretsried
 GERMANY
 Phone +49 8171 9673 0
 Fax +49 8171 9673 10
 E-Mail buero@oli-gmbh.de
www.oli-gmbh.eu

