

metal detector

MFN11 + conveyor 60



metal detector **MFN11** + conveyor 60



4.0
Ready
Systems

BRCS

In
Partnership
with



discover
all the details
on our web-site!



Technical Specifications

Weighing range	up to 10000 g
Linear speed	up to 65 m/min
Pneumatic supply	0,6 Mpa
Power supply	230V 50/60Hz single phase
Power consumption	650 W
Mirror finishing of metal parts	Stainless Steel IP54 - IP65
Climatic environment	from 5°C up to +40°C non-condensing (closed)

Electronics

- Digital electronics with alphanumeric graphic display
- 100 storable product programs



Equipment

- Adjustable speed
- 3 levels password access protection
- Principle of operation: digital with bidimensional image
- Working multifrequency
- One RS232 serial port
- Phase adjustment function
- Function and process alarm output
- High immunity to environmental interferences
- Fail-safe mode
- Very high sensibility to all magnetic and not magnetic metals, stainless included
- Visualization of product image
- Rejects printouts
- Automatic balancing
- Self-check function
- OK pcs. and rejects totalizer
- Report archive
- Date/Time function
- Automatic product compensation (Tracking)
- Production data management in conformity with the standards in force
- In conformity with ISO - FDA - HACCP - GMP - CE regulations and international standards for Electrical Safety and Electromagnetic Compatibility

Optional

- Rejection systems
- Reject management systems
- Stainless steel rejection bin
- Wind-prevention tunnel
- Quick-disassembly belt
- Special conveyors
- Alarms notification
- Product presence and synchronism system photocell
- Ejection check photocell
- Wheels
- Separated electronic equipment
- Ethernet Interface for Industry 4.0 compliance
- USB interface
- Products programs memory expansion
- FAT/SAT, IQ/OQ validations

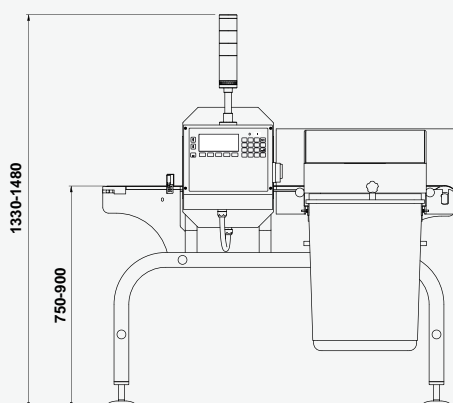

RUNNING DIRECTION TO CLIENT'S SPECS

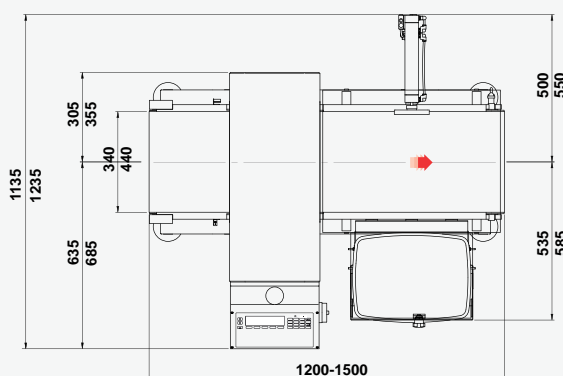

The manufacturer reserves the right to change the product specifications without notice. The image and the drawing are indicative of one of the possible configurations of the machine.

© PRISMA INDUSTRIALE S.r.l. cod. B0034 rev.005

PRISMA
PARMA ITALY